

# ELEGANCE EL1203



*Low Carbon Fan with EC Motor  
Installation and Operating Instructions*



- **3 models:**
  - 3 speed continuous running
  - timer
  - humidity control
- **for all domestic wet rooms**
- **for walls or ceilings**

CE  IPX4

# “Elegance EL1203” - HIGH PERFORMANCE, LOW CARBON FANS INSTALLATION and OPERATING INSTRUCTIONS

## THIS LEAFLET MUST BE AVAILABLE TO THE USER

The product you have purchased is an extractor fan for exhausting directly outside or through medium lengths of ducting and is suitable for wall or ceiling installation. To ensure optimum operation and guarantee a long life, please read this manual carefully. It explains how to install correctly, use and maintain the product properly. Following these instructions will ensure the reliability of the product and extend its working life.

**The manufacturer will not be held responsible and will not accept any responsibility for damage caused to persons or things due to improper use with reference to the precautions outlined in this leaflet.**

The product, constructed using state of the art technology, complies with current standards regarding electrical equipment. It conforms with the EMC 2014/30/UE European Directive regarding radio interference suppression and electro-magnetic compatibility.

### **WARNING: Serious injury or death could result if these instructions are not carefully followed**

- Do not use this product for any purpose other than that for which it was designed.
- Remove the product from its packaging and make sure that it has not been damaged. If in doubt, contact the supplier, authorised dealer, service centre or manufacturer to check that the product will still operate correctly. Do not attempt to use or repair the product before doing this.
- Do not leave packing material within the reach of children or unskilled people. To dispose of the packaging and the appliance at the end of its useful life refer to the recycling rules in force.
- The use of any electrical product requires compliance with some basic rules which are listed below:

- do not touch it with wet or damp parts of the body (eg hands, feet).
- this appliance can be used by children aged 8 years and over, and people with reduced physical, sensory or mental capabilities or lack of experience and knowledge **if** they have been given supervision or instruction concerning use of the appliance in a safe way **and** understand the hazards involved. Children shall not play with the appliance. Cleaning and user maintenance should not be carried out by children without supervision.

- The product should be connected to the mains electricity supply or electrical outlet only if:
  - the electrical voltage and frequency correspond to those shown on the rating label.
  - the capacity of the electricity supply is sufficient to operate the product at its maximum power.
  - suitable electrical protection is provided for the product to be installed.
- The electrical supply to which the fan is connected must comply with all existing regulations. All installations must comply with current IEE wiring regulations.
- Before maintenance or cleaning is carried out, the product must be switched off and disconnected from the mains electricity supply.
- If a fault, malfunction or anomaly of any type occurs, the fan should be isolated (switching it off and disconnecting it from the mains electricity supply) and advice sought from qualified personnel.
- Always request original spare parts for repairs.
- If the product needs to be removed, turn off the mains supply circuit-breaker and then disconnect the fan.
- The fan **MUST BE** installed as detailed in this leaflet.

**WARNING: Damage could be caused to the product if the installation instructions are not followed**

- The product should **not** be used in an ambient temperature higher than 40°C (104°F).
- The product should **not** be exposed to atmospheric agents (rain, sun, snow, etc.).
- The product or its parts should **not** be placed in water or other liquids.
- Routine maintenance as described below should be carried out to check the condition of the fan.
- The air or fumes being extracted must be clean and free from greasy particles, soot, chemical and corrosive agents, flammable or explosive mixtures.
- The product must be installed by professionally qualified personnel. Incorrect installation can cause damage to people, animals or property, for which the manufacturer cannot be held liable.**
- The product must be connected to the electricity supply via a double pole switch of a suitable size, with contact openings of at least 3 mm.
- If the electrical supply board (or switching device) is located some distance from the fan a means of local isolation must be provided.
- To ensure optimum operation, do not block the air intake and exit vents.
- Any ducting used must be free of blockages, and should be insulated if in an unheated area.
- The room where the product is operating must have adequate air replacement to ensure maximum effectiveness.
- If the product is sited in a room containing a fuel burning appliance which is not of the balanced flue type, the installer must ensure that air replacement is adequate both for the fan and the fuel burning appliance
- The product must **not** be used as an activator for water heaters, stoves, etc.
- The product must **not** exhaust into ducts designed to evacuate fumes from combustion in stoves or other combustion-powered devices.

**RANGE**

**Trickle Speed 1 - 13 lt/sec - 47 m³/h**

**Trickle Speed 2 - 19 lt/sec - 68 m³/h**

**EL1203** - this fan combines the latest technology with energy saving and efficiency. It is a quiet running, 3 speed fan. It is designed to run continuously at a pre-selectable choice of 2 trickle speeds (fixed at installation). The user can boost the fan speed to its maximum performance when required by means of a remote switch, light switch, PIR sensor or humidistat.

**EL1203DT** - 3 speed, continuous running fan with delay-on timer. The delay-on timer version will run at low speed until the boost speed is activated by means of a remote switch, light switch, PIR sensor or humidistat. There is a 2 minute delay before the fan starts to run at its high speed - if the boost speed is deactivated before that time lapse, the fan will continue to run at low speed. If the boost speed is activated, the fan will operate at high speed until the boost switch is turned off. After this, the fan will continue at high speed for the length of time set on the timer overrun adjustment, between 0 and 30 mins. (See page 8). After the overrun time has elapsed, the fan will return to the slower speed.

**EL1203HDT** - 3 speed, continuous running fan. The fan runs continuously at the pre-selected lower speed, and the boost (speed 2) will start to operate automatically when the relative humidity (adjustable between 40% and 90% +/-5% tolerance) reaches the pre-set level and will continue to operate at this speed until the humidity has been dispersed and the adjustable over-run timer (adjustable from 0 to 30 minutes) has completed its cycle. The boost speed can also be activated by as described for model EL1203DT

# INSTALLATION

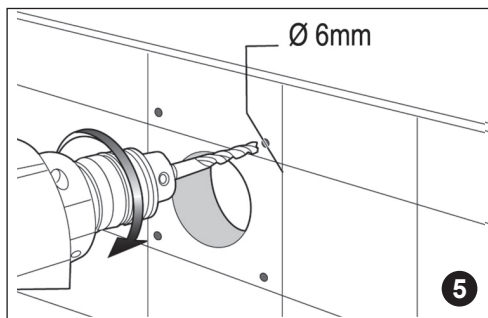
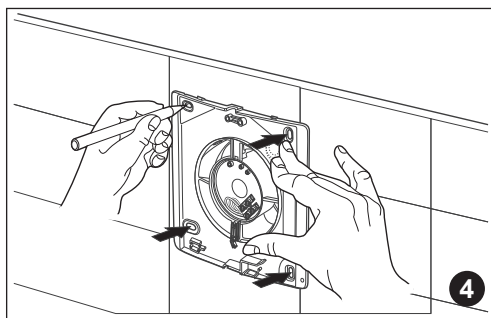
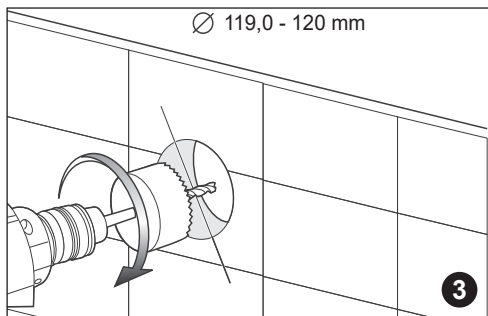
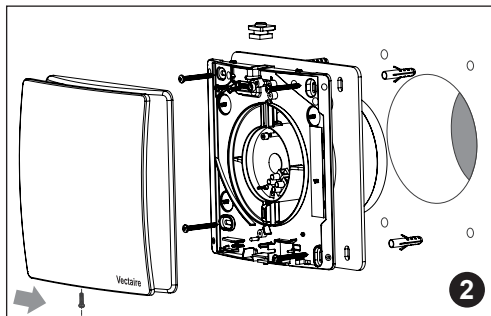
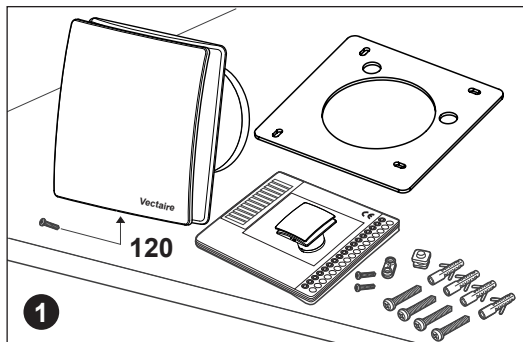

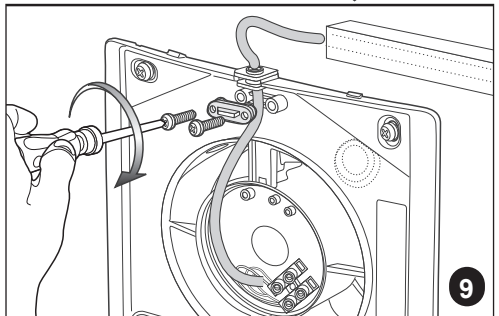
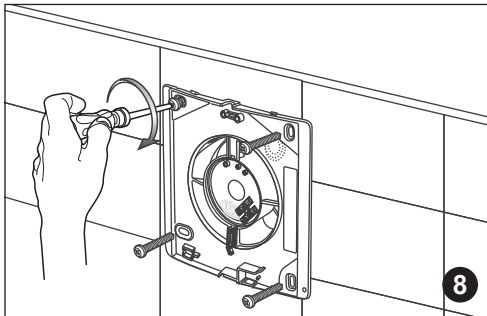
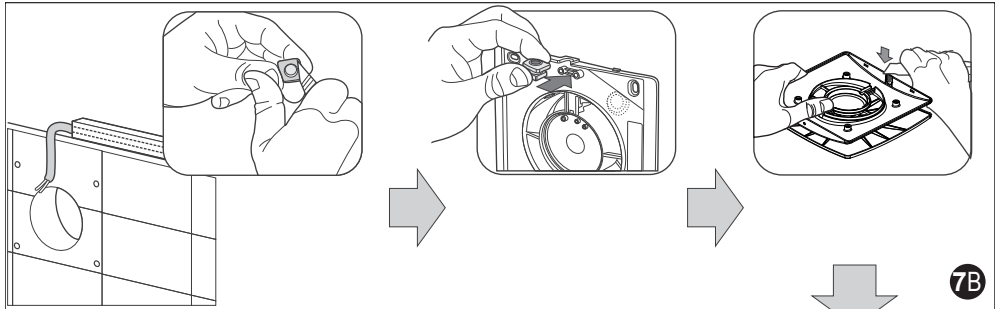
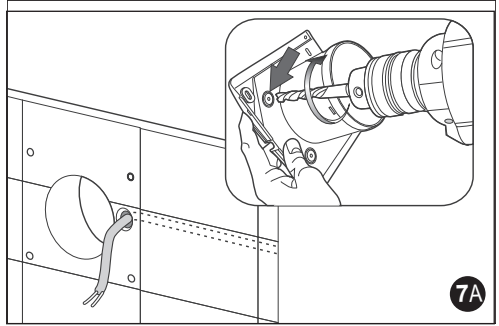
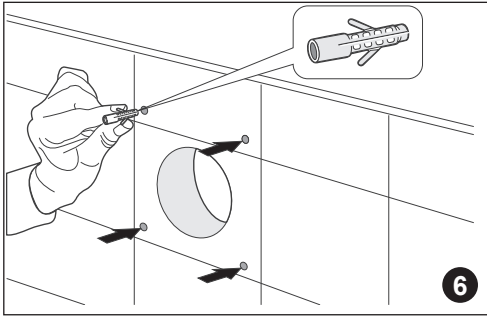

## INSTALLATION

1. check there is nothing missing in box.
2. remove front cover.
3. drill hole in wall - **allow extra width if using ducting - it is the installer's responsibility to use the appropriate core cutter to obtain the correct hole diameter.**
4. use fan assembly as template to mark drill hole
5. drill 4 x 6mm dia holes
6. fit wall plugs
7. decide whether to have cable access from rear (recessed see dia. 7/A) or top (surface) of fan - if from top ensure that included grommet is properly fixed (see dia.7/B).
8. screw fan to wall
9. connect cable using cable clamp (see dia 9).  
**N.B. this fan is double insulated and does not need to be earthed**
10. replace front cover and screw on firmly

**N.B. This fan is NOT suitable for use with a Gravity Grille. It should be installed using either a Cowl or Fixed Grille.**

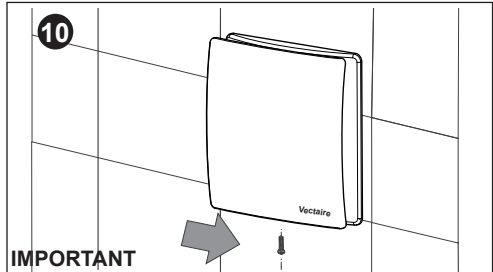

### IMPORTANT

If the fan is installed in a ceiling with a vertical duct passing through an unheated space, a condensation trap **MUST** be fitted. Any ducting in an unheated space should also be insulated according to the latest Building Regulations recommendations in the Domestic Ventilation Compliance Guide.

Failure to do this could result in condensation affecting the operation of the fan and cause damage to the ceiling.



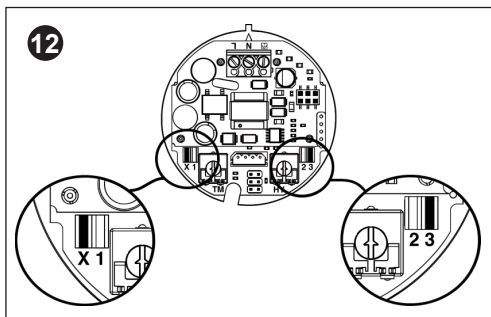
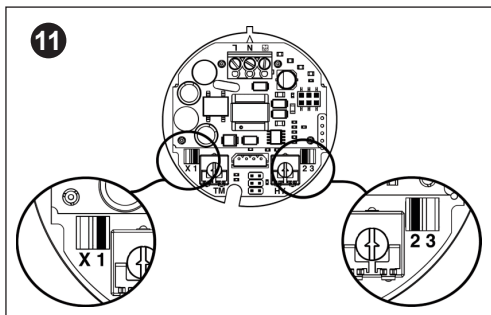

## WIRING DIAGRAMS

Els - 3 speed via remote switch

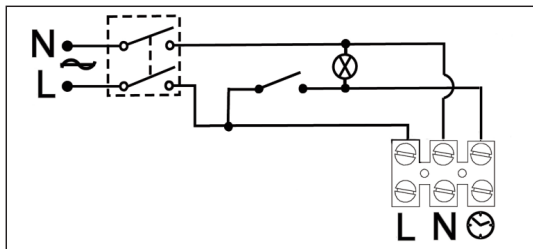

## JUMPER SWITCH

These fans are designed to run continuously at one of 2 lower speeds fixed at installation using the jumper switch.

**EL1203, EL1203DT and EL1203HDT** (fig 11)

Minimum Speed 1 - Jumper 1

Minimum Speed 2 - Jumper 2

To activate delay-on timer in EL1203DT and EL1203HDT plug Jumper on position 3 (fig 12)

The user can boost the fan speed to its maximum performance by remote switch .

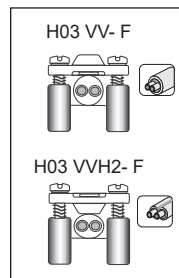

## TRIMMER ADJUSTMENT

To adjust the humidistat and timer trimmers, remove the front cover of the fan (fig13) to access the trimmers.

The humidistat (HY) can be adjusted between 40% and 90% relative humidity. Turn clockwise to decrease sensitivity and set at a higher level of relative humidity. The timer (TM) is adjustable between 0 and 30 minutes. Turn the trimmer clockwise to increase the overrun time, or anti-clockwise to decrease it.

## MAINTENANCE

Before any maintenance or cleaning operation, switch off the fan and disconnect it from the main power supply. The front cover can be cleaned with a dry cloth or soft brush. The fan must not come into contact with any kind of liquid or solvent. If this should occur, contact a qualified technician before reassembling the fan.

**NOTE: The motor does not require lubrication as it is maintenance free “sealed for life” type.**

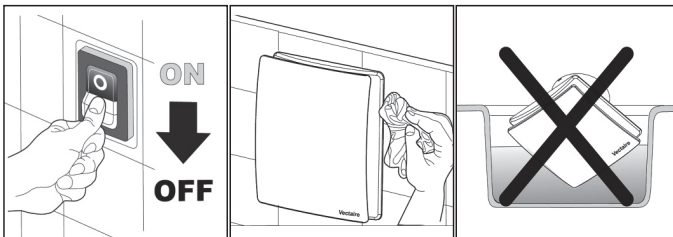
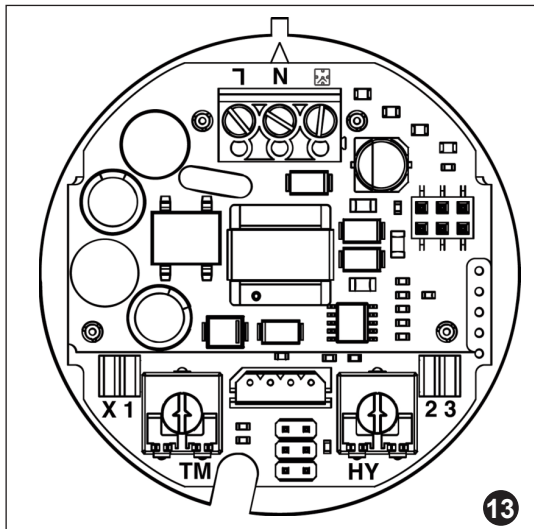

## DISMANTLING & RECYCLING

This product has been designed and constructed using high-quality materials and components that can be recycled or re-used.

Vectaire Ltd, Lincoln Road, Cressex Business Park, High Wycombe, Buckinghamshire, HP12 3RH  
Tel: +44 (0)1494 522333. Fax: +44 (0)1494 522337. Email: [sales@vectaire.co.uk](mailto:sales@vectaire.co.uk) Web: [www.vectaire.co.uk](http://www.vectaire.co.uk)